

©2016 T-O ENGINEERS. THIS INSTRUMENT IS THE PROPERTY OF T-O ENGINEERS. ANY REPRODUCTION, REUSE OR MODIFICATION OF THIS INSTRUMENT OR ITS CONTENTS WITHOUT SPECIFIC WRITTEN PERMISSION OF T-O ENGINEERS IS STRICTLY PROHIBITED.

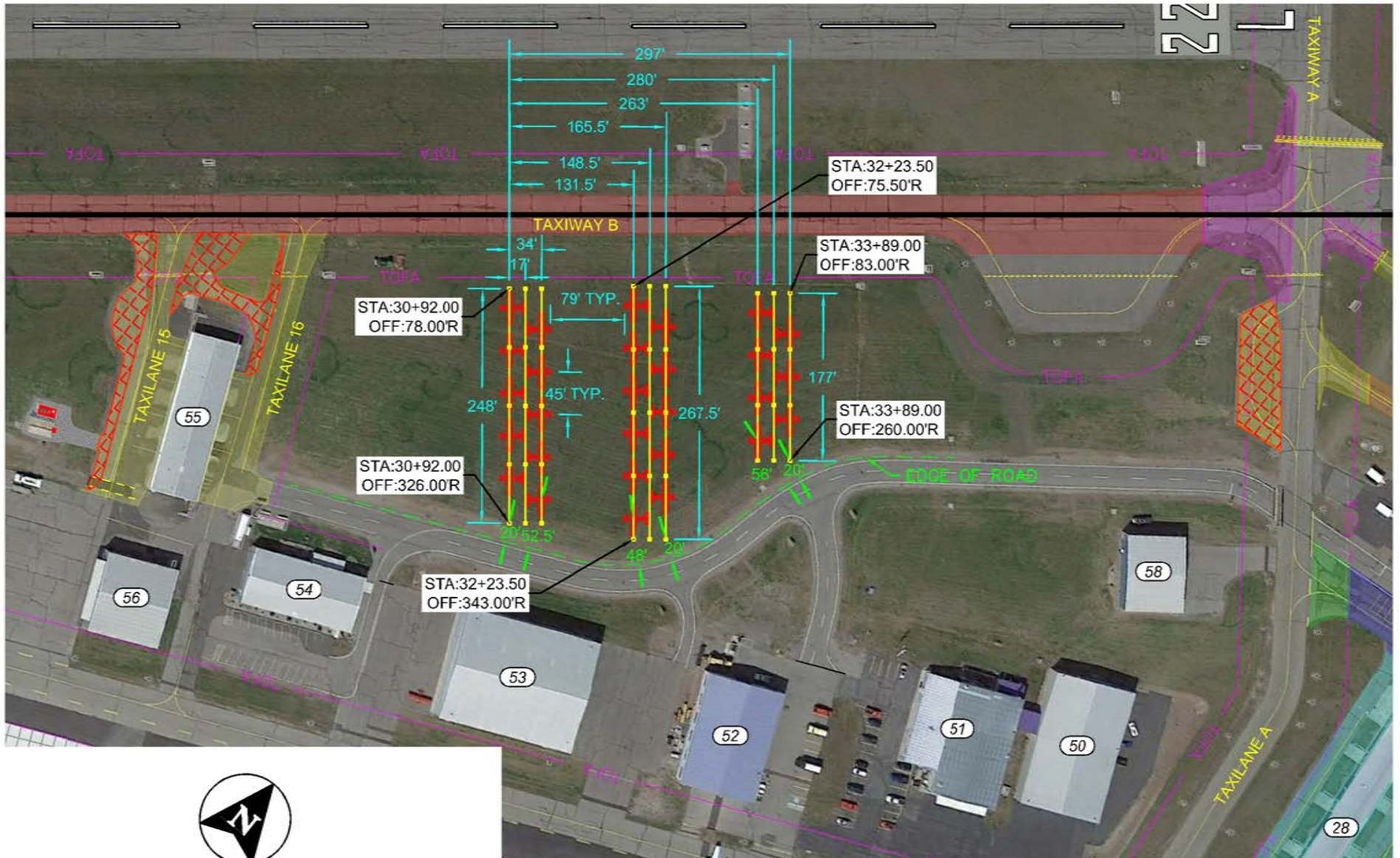

SCALE: 1" = 150'

**PARKING LAYOUT BASED ON:**  
 (28) CESSNA 182  
 WINGSPAN: 36'  
 LENGTH: 29'



WEST 280 PRAIRIE AVENUE  
 COEUR D'ALENE, IDAHO 83815-7710  
 PHONE: (208) 762-3644 FAX: (208) 762-3708  
 E-FILE: Parking Layout DATE: April 26, 2016 JOB: 140061



©2016 T-O ENGINEERS. THIS INSTRUMENT IS THE PROPERTY OF T-O ENGINEERS. ANY REPRODUCTION, REUSE OR MODIFICATION OF THIS INSTRUMENT OR ITS CONTENTS WITHOUT SPECIFIC WRITTEN PERMISSION OF T-O ENGINEERS IS STRICTLY PROHIBITED.

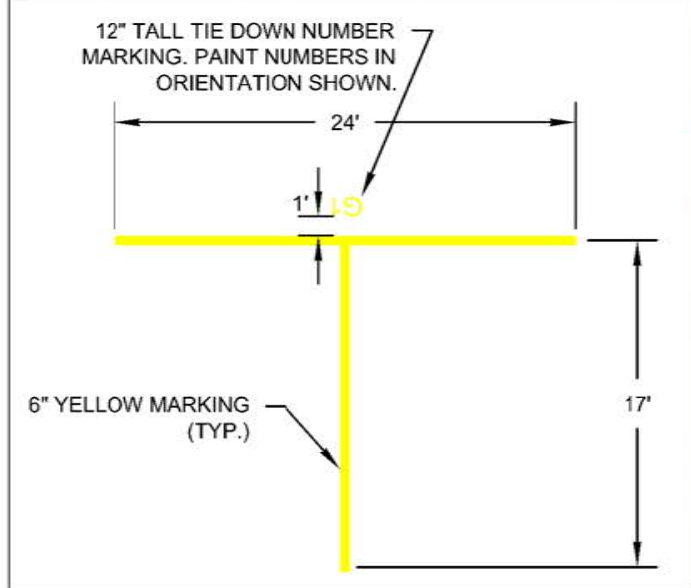

TIE DOWN MARKING DETAIL NTS

## NOTES

1. TIE DOWN MARKINGS AND TOFA SHALL BE PAINTED PRIOR TO EACH PHASE.
2. TIE DOWN NUMBERS SHALL BE PAINTED PARALLEL TO AND 1-FOOT FROM TIE DOWN MARKING. TIE DOWN NUMBERS SHALL BE SOLID YELLOW WITH NO GAPS OR BLOCK OUTS. NUMBERS SHALL BE 12-INCHES TALL WITH A 2-INCH SPACING BETWEEN CHARACTERS.



SCALE: 1" = 60'

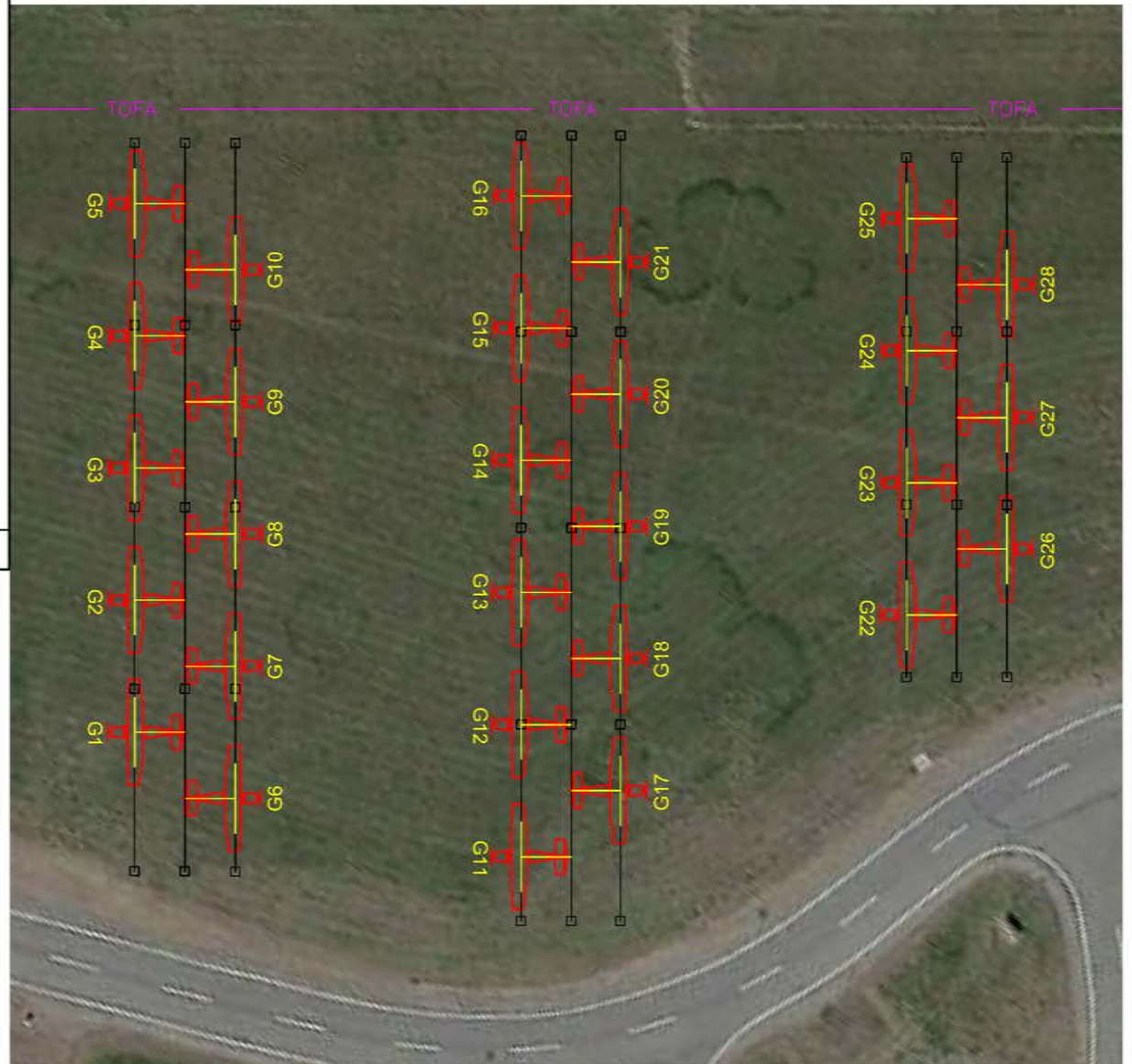

WEST 280 PRAIRIE AVENUE  
 COEUR D'ALENE, IDAHO 83815-7710  
 PHONE: (208) 762-3644 FAX: (208) 762-3708  
 E-FILE: Parking Layout DATE: April 26, 2016 JOB: 140061

DRAFT

J:\140061\Reports\Construction\RFI\16.03.28 - RFI No. 44 - Temporary Tiedowns (Exhibit REVISED).dwg, 4/26/2016 11:12:26 AM, Schreindl, Jeremiah, Bluebeam PDF10 Printer HighRes.pc3

© 2016 T-O ENGINEERS. THIS INSTRUMENT IS THE PROPERTY OF T-O ENGINEERS. ANY REPRODUCTION, REUSE OR MODIFICATION OF THIS INSTRUMENT WITHOUT SPECIFIC WRITTEN PERMISSION OF T-O ENGINEERS IS STRICTLY PROHIBITED.

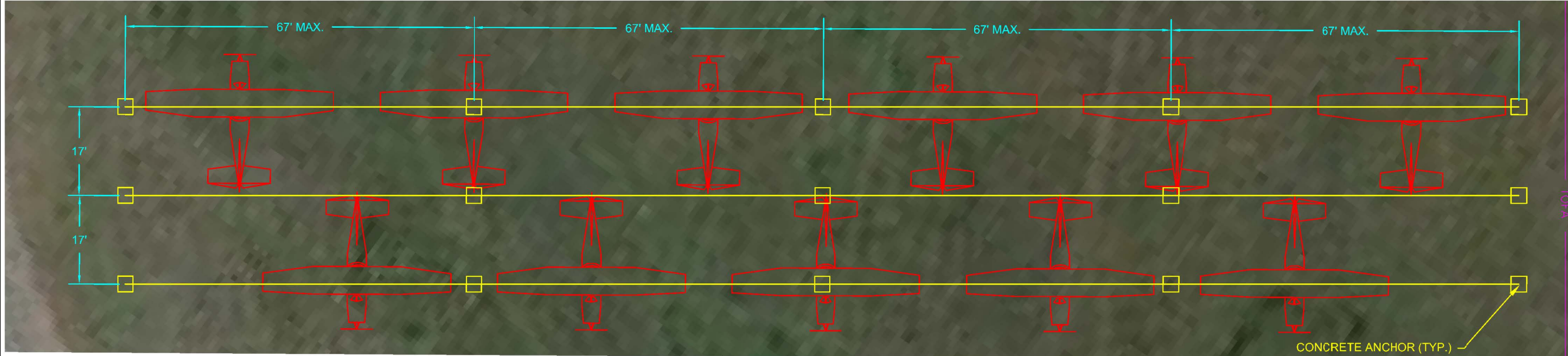

PLAN VIEW  
NOT TO SCALE

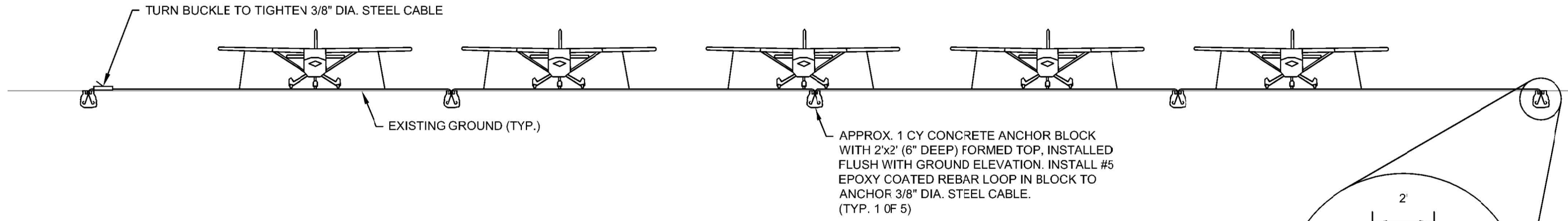

PROFILE VIEW  
NOT TO SCALE

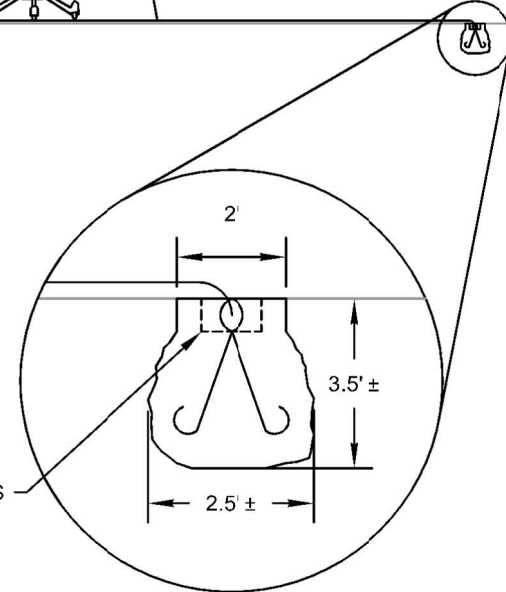

BLOCK DETAIL  
NOT TO SCALE



WEST 280 PRAIRIE AVENUE  
 COEUR D'ALENE, IDAHO 83815-7710  
 PHONE: (208) 762-3644 FAX: (208) 762-3708  
 E-FILE: Parking Layout DATE: April 26, 2016 JOB: 140061

TOFA